



Operating Instructions
in compliance with
Pressure Equipment Directive 2014/68/EU
and
Pressure Equipment (Safety) Regulation 2016,
UK Statutory Instrument 2016 No. 1105

Cast iron valve DN125



Please read these operating instructions carefully to ensure a safe operation and keep the same for further use.

© 2024 Armaturenwerk Altenburg GmbH | Am Weißen Berg 30 | 04600 Altenburg, Germany



Table of content

Safety.....	4
Authorized personnel.....	4
Residual hazards.....	4
Symbols used for safety information.....	4
General safety information.....	5
Other information.....	5
Description of valve.....	6
Types.....	6
Operating principle.....	7
Product description.....	7
Identification.....	8
Technical parameters.....	8
Design features.....	9
Transport and Storage.....	9
Mounting.....	10
Principles.....	10
Mounting preparation.....	11
Connecting the system and compressor.....	11
Commissioning.....	11
Principles.....	11
Steps of commissioning.....	12
Operation, Maintenance and Repair.....	13
Principles.....	13
Repairs.....	13
Dismantling and Disposal.....	14
Principles.....	14

Safety

The Cast iron valve DN125, hereinafter referred to as valve, is designed for use in refrigeration/air conditioning systems, hereinafter referred to as systems. It may only be put into service if installed in the system unchanged in accordance with these instructions and in its entirety is in compliance with the statutory provisions.

The valve incorporates state-of-the-art technology and has been built according to the applicable regulations. Great value has been set upon the user's safety.

These operating instructions are integral part of the contract and shall be kept throughout the entire life of the valve.

Authorized personnel

Only trained and instructed personnel shall be allowed to do any work on the valve and system. As regards the qualification and expertise of the personnel the applicable rules and guidelines shall apply.





Residual hazards

Unavoidable residual dangers may emanate from the valve. Every person working on this device shall therefore carefully read these instructions!

To be observed are for example:

- the generally accepted safety regulations,
- EC directives,
- Norms (e.g. EN 378) and all national provisions.





Symbols used for safety information

	DANGER! Instructions on preventing imminent serious dangers to persons. Imminent most serious injuries or death as a possible consequence. Any non-observance may lead to an immediate failure of the valve.
	WARNING! Instructions on preventing potential serious danger to persons. Avoidable serious to very serious injuries or death a possible consequence. Any non-observance may cause the valve to fail.
	CAUTION! Instructions on preventing a minor danger to persons. Minor, reversible injuries cannot be excluded. Any non-observance may lead to a medium-term failure of the valve.
	ATTENTION! Instructions on preventing potential damage to equipment. Minor, reversible injuries cannot be excluded. Any non-observance may lead to a medium-term failure of the valve.

General safety information

These operating instructions are based on the safety requirements of EN 378-2 and EN 21922.

Instructions to prevent hazards in all cycles of service life:

	<p>DANGER! Risk of bursting if operated beyond the technical parameters. Most serious injuries and immediate system failure possible. Observe the technical parameters.</p>
	<p>WARNING! Damage due to improper handling. Serious injuries and system failure possible. Never use valves as transport, lifting or lashing points.</p>
	<p>WARNING! Any non-observance of the instructions may cause the valve to fail. Avoidable serious to very serious injuries or death possible. Installation, operation and maintenance by authorized personnel only.</p>
	<p>WARNING! Risk of service fluid to be released. Depending on the kind of service fluid serious to very serious injuries or death possible as a consequence. Wear personal protective equipment (e.g. respirators, gloves).</p>
	<p>CAUTION! Very cold or very hot surface temperatures possible. Frostbites/burns possible. Wear personal protective equipment (e.g. respirators, gloves).</p>

Other information

The information contained herein represents to the best of our belief our knowledge at the time when these instructions were prepared. It shall serve as code of practice to ensure a safe handling of the valve in transport, storage, installation, commissioning, maintenance and dismantling/disposal. A final decision as to whether the valve suits the purpose is to be taken by the user. This information shall not be deemed a warranty of quality.

Any modification of the valve and operation under other than the prescribed parameters shall not be allowed and will result in the loss of the conformity declaration and all liability claims.

Description of valve

Types

Valve for mounting on compressor in angular form with protective spindle cap.

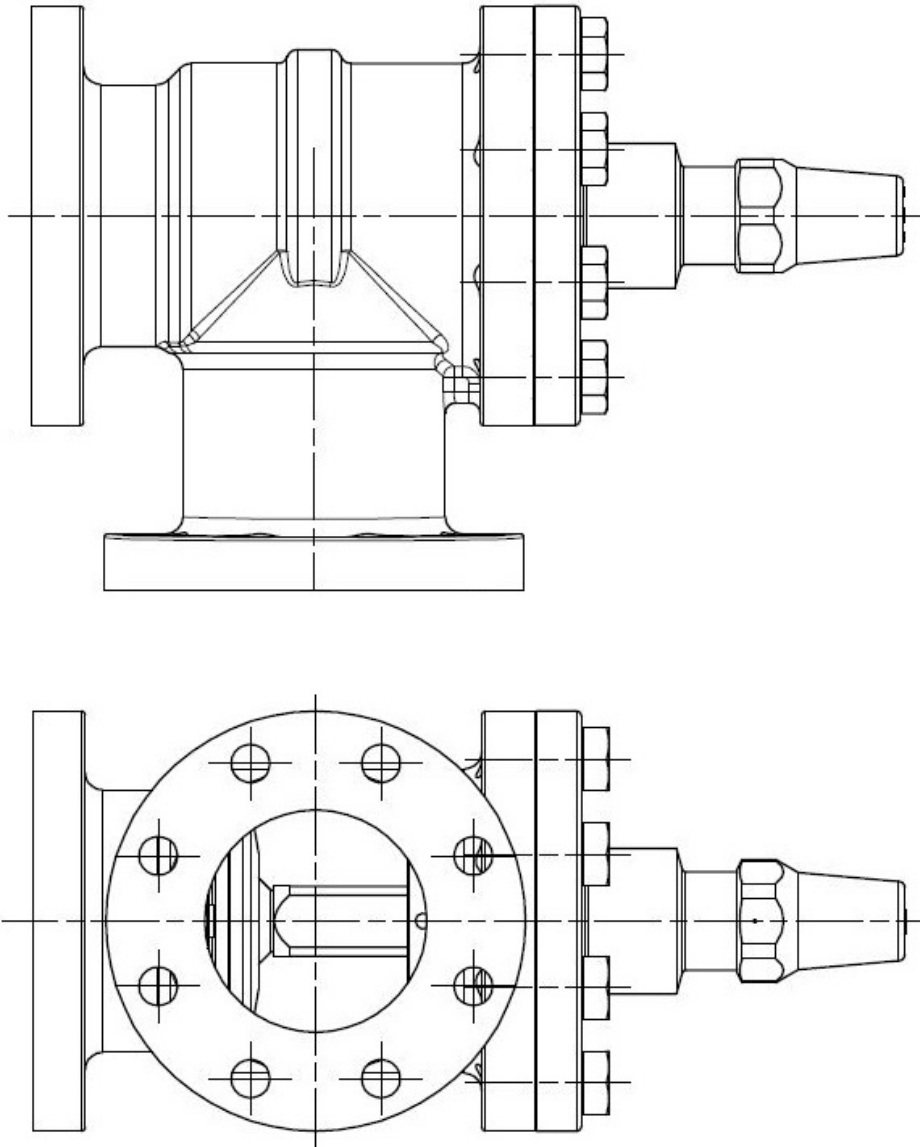

The valves come with two flange connections.

Installation dimensions can be gathered from the AWA product catalogue and technical documents respectively. The connecting options are explained in more detail in “Design features”.

Operating principle

Spindel auf Ventilsitz geschlossen
Spindle position on valve seat closed

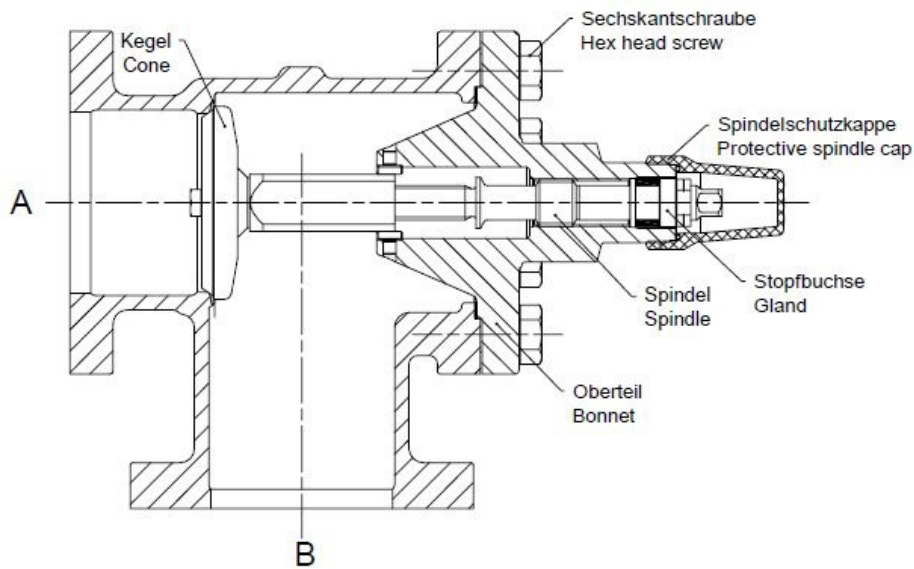

Spindel geöffnet
Spindle position open

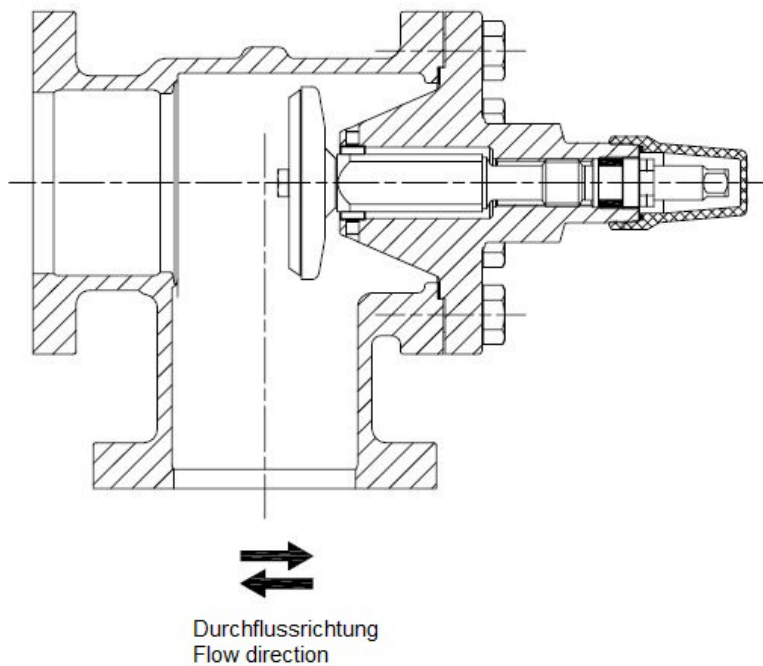

Product description

The valve is a manual angle valve designed for installation in refrigeration or air conditioning systems.





The flow direction are optional.

The valve is in compliance with EN 21922, the Pressure Equipment Directive 2014/68/EU and the Pressure Equipment (Safety) Regulation 2016, UK Statutory Instrument 2016 No. 1105.

For the valve DN150 a type examination according to 2014/68/EU and PE(S)R 2016 module B is available.

Identification

The valve is marked in accordance with EN 21922 by marking and name plate:

Armaturenwerk Altenburg GmbH 	
Typ: Cast Iron Valve AWA-Part-Nr.: 71205x000 Material: EN-JS 1025 Normal size: DN125	 
Operating range: PS -1...35 bar TS -10...140°C PS' -1...21 bar TS' -40...-10°C Fluids: Refrigerants EN378-1 (2020) PED Fluid group 1 and 2	
Year of manufacture - Serial number: Made in Germany	2024-yyyy

Technical parameters

Allowable pressure/ temperature / service fluids:

Maximum allowable pressure PS: PS 35bar PS 26bar
 Allowable temperature TS: TS -40 ... 150°C TS' -60 ...-40°C

Permitted service fluids:

Standard: Refrigerants acc. to EN378-1 (2020) Safety Group A1 to A3 and B1
 (PED Fluid Group 1 and 2)

Ammonia on request: Refrigerant acc. to EN 378-1 (2020) PED fluid groups 1 and 2

Leakage test:

according to DIN 8964-3 (<4,1 g/a R-134a at 10bar)

Strength test:

according to EN 21922 at 1.5fold PS

Cleanliness of interior:

according to DIN 8964-1

Classification pursuant to Pressure Equipment Directive 2014/68/EU and PE(S)R 2016:

Category III

Approval under UL 207

The valves are UL 207 approved for the US and Canadian market.

Design features

- The material of the valve components and the manufacturing method are selected in conformity with the EN 21922, the Pressure Equipment Directive 2014/68/EU, the Pressure Equipment (Safety) Regulation 2016 and the RoHS Directive 2011/65/EU thus guaranteeing the reliability for the operating range indicated.
- The valve housing and bonnet material of cast iron (EN-GJS-400-18-LT) provides for both a high degree of media compatibility and corrosion resistance.
- The flow can pass the valve in both directions. The recommended flow direction with optimum cv-value is the flow onto the valve cone (flow direction from A to B).
- The valve cone is equipped with a soft-material seal and is moved by a double spindle thread.
- The valve spindle is designed with a square for actuation and has a metal back sealing function. The latter is only operative when the valve is fully open. The sealing between spindle and housing is by a graphite packing and adjustable gland seal.
- The valve is supplied as standard with a pressure-tight stem protection cap with pressure relief device.
- Types of connection:
 - Connection "A" System** – Flange connection (8x tapped holes M20 on bolt circle Ø195mm) for mounting of a specific counter flange with flat gasket.
 - Connection "B" Compressor** – Flange connection (8 through holes Ø22 on bolt circle Ø195mm) for mounting of a specific counter flange with flat gasket.
- When supplied the valve has a 2 layer coating for normal corrosion exposure. This coating provides corrosion protection until installation provided handling and storage takes place in dry condition.
- The service-friendly design makes it possible to purchase spare parts (Bonnet, protective spindle cap, gaskets) separately.

Transport and Storage

Transport the valve by closed means of transport in the original packing protected against weather influences and store it in dry rooms.

Mounting

Principles

- The valve (weight approx. 51kg) shall be arranged in the system so that it can be properly installed, operated and maintained. Depending on the weight, installation aids must be provided.

	DANGER!	
	Damage to valve possible. Serious injuries and system failure during operation possible. Valve to be installed without additional loads (forces, vibrations etc.). Never use the valve as fixing points of pipes.	

- The dismounting space for mounting, spindle actuation or maintenance of the bonnet must be provided according to the table.

Nominal size	Removal space
DN125	> 300mm
- It must be possible to apply the necessary torques to operate the spindle (opening and closing) in a safe manner.
- The flow can pass the valve in both directions. The recommended flow direction with optimum cv-value is the flow onto the valve cone (flow direction from A to B).
- The valve should be installed with the valve spindle in a horizontal position or with the valve spindle vertical upwards.
- The valve must be integrated into the pipe on both sides. An outlet side open to the outside is not permitted!
- Only authorized personnel shall be allowed to mount the valve.

	DANGER!	
	Any non-observance of these instructions may cause the valve/system to fail. Most serious injuries and death possible. Mounting and operation by personnel trained in refrigeration systems only.	

- No modifications of the valve permitted. If modifications become necessary, they have to be agreed with the manufacturer in writing prior to mounting.

	WARNING!	
	Product features may change. Avoidable serious to very serious injuries or death possible. Any modification of the valve has to be agreed with manufacturer in advance.	

Mounting preparation

- When supplied the valve is closed and comes with additional protective means for transport. To avoid corrosion inside the valve and contamination, such protective means should be removed shortly before mounting.

	<p>ATTENTION! Damage to interior components possible. Malfunction due to oxidation/contamination of interior components. Wait to remove the transport protection until shortly before mounting.</p>
---	---

Connecting the system and compressor

- Prepare the connections so (bare metal and free of damage) that a high-quality joint can be achieved.
- The compressor and the flange of the system connection must match the specifications of the compressor manufacturer. Mount the valve on the compressor using the mounting material specified by the compressor manufacturer. Then make the flange connection to the system. Make sure that the installation is free of mechanical constraints.
- Initially screw the nuts/bolts hand-tight. Then tighten the nuts/bolts crosswise in at least 2 stages to the specified tightening torque.
- Depending on the intended condition the spindle must be fully opened or fully closed. Before moving the spindle, loosen the stuffing box by $\frac{1}{4}$ turn. Then, tighten the gland at the required torque (leakage check). Thereafter, screw on the protective spindle cap.
- If a subassembly is to be mounted, shut the pipe ends using dust caps until further use.
- The following torques apply to the valve assembly (Nm):

Valve size	Spindle closed	Spindle opened	Protective spindle cap	Screws Bonnet	Packing gland
DN125	200 +10	100 +10	35 +5	340 +10	80 +10

	<p>WARNING! Any excessive torques or non-observance of the mounting sequence may cause failures. Serious injuries and system failure during operation possible. Observe the torques.</p>
---	--

Commissioning

Principles

- The valve have already been tested for leakage and strength by the manufacturer.
- The valve and the system into which it is installed, may only be commissioned if they have been checked, with due regard to the intended mode of operation, for proper condition as to assembly, installation, set-up conditions and safe functioning.
- After mounting and initial start-up according to EN 378-2:2016 by check again for leakage and strength and effective corrosion protection.

Steps of commissioning

- Check the system for leakage and pressure resistance by suitable means (e.g. helium, dry nitrogen).

	DANGER!
	Risk of valve bursting. Most serious injuries possible. The maximum allowable pressure (PS) must not be exceeded! Strictly observe the safety information (e.g. EN 378).

Exception: Exceeding a maximum of 1.1 x PS for a short period of time until the pressure relief device responds (see EN378-2, ISO 5149-2).

- It may be necessary to apply an adapted corrosion protection that goes beyond the normal corrosion stress. Damage to the paint due to assembly must be repaired. Make sure that the fabrication data remain legible.

	CAUTION!
	Delayed failures due to corrosion possible. Serious injuries and system failure during operation possible. If necessary apply a suitable anticorrosive coating.

	ATTENTION!
	Loss of product conformity due to loss of name plate/markings. Loss of warranty. Marking must be legible.

- Evacuating and filling the system with refrigerant.

	DANGER!
	Risk of bursting if operated beyond the technical parameters. Most serious injuries possible. Observe the technical parameters of the valve. Avoid excessive filling of the system with refrigerant.

Depending on the intended condition the spindle must be fully opened or fully closed. Before moving the spindle, loosen the stuffing box by ¼ turn. Then, tighten the gland at the required torque (leakage check). Thereafter, screw on the protective spindle cap. (torques see "Mounting")

	WARNING!
	Exceeding the tightening torques can lead to damage. Serious injuries and system failure during operation possible. Observe the torques.

- Upon initial commissioning check the pipes for any abnormal vibration and record the operating data.

	CAUTION!
	Cracks of the piping and the valve due to dynamic loads possible. Injuries and system failure during operation possible. Avoid heavy vibrations. Take safety measures if need be.

Operation, Maintenance and Repair

Principles

- The valve is maintenance-free.
- As part of the regular system inspection it should be checked for corrosion/damage/tightness and operability and its proper condition restored if necessary.

WARNING!

Media contact possible, contact with hot/cold surfaces.
Burns, frostbites.
Wear personal protective equipment during maintenance and inspections as prescribed by national regulations.

- If the valve spindle is to be operated for system maintenance, carefully remove the protective spindle cap.

WARNING!

Protective spindle cap is pressure-tight and may be pressurized.
Serious injuries possible.
Slowly remove the cap. Allow any service fluid escape from inside the cap if necessary.

If it is not possible to achieve a pressure compensation, firmly screw the protective spindle cap again and apply the prescribed torque. If so, there is a malfunction of the valve and it will be necessary to check or replace the packing gland (see Repair chapter).

- Depending on the intended condition the spindle must be fully opened or fully closed. Before moving the spindle, loosen the stuffing box by ¼ turn. Then, tighten the gland at the required torque (leakage check). Thereafter, screw on the protective spindle cap. (torques see “Mounting”)

DANGER!

Risk of valve bursting.
Most serious injuries possible.
The test pressure must not exceed the maximum allowable pressure (PS).
Strictly observe the safety regulations (e.g. DIN EN 378).

Repairs

- If a proper functioning of the valve is no longer guaranteed, switch the system off, drain the refrigerant from the system (or system section) in an eco-friendly manner and vent the system (or system section).

DANGER!

Refrigerant may escape.
Leaking refrigerant may cause most serious injuries.
For repairs the system must have the right temperature, free from refrigerant and sufficiently ventilated.

- The valve housing is beyond repair. A faulty valve housing must be removed from the system and replaced by a new one.
- For repairs (bonnet, protective spindle cap, gaskets) use no other than original spare parts. When removing/installing the bonnet of the valve, a new bonnet gasket must always be used.

WARNING!

Valve damage due to defective spare parts/mounting.
Avoidable serious injuries and system failure possible.
Use no other than original spare parts for repairs.

- Install/commission according these instructions. It is imperative to carry out another leakage and strength test. No warranty is accepted by AWA for tightness in case of repair.

Dismantling and Disposal

Principles

- To dismantle the valve, shut off the system, remove the refrigerant from the system (or system section) in an environmentally friendly manner and sufficiently vent the system (or system section).



DANGER!

Refrigerant may escape.
Leaking refrigerant may cause most serious injuries.
For repairs the system must have the right temperature, free from refrigerant and sufficiently ventilated.



WARNING!

Media contact possible, contact with hot/cold surfaces.
Burns, frostbites.
Wear personal protective equipment during maintenance and inspection as prescribed by national regulations.

- The valve and its components can be recycled:
 - Valve housing, bonnet: cast iron scrap
 - Spindle, valve cone: stainless steel scrap
 - Protective spindle cap: aluminium scrap
 - Dust caps: plastics (PE)



Armaturenwerk Altenburg GmbH

Am Weißen Berg 30
04600 Altenburg

Telephone +49 (0) 3447-893-0
Telefax +49 (0) 3447-811-10

Internet: <http://www.awa-armaturenwerk.de>
Email: info@awa-armaturenwerk.de

Subject to change as of: 06/2024
Document 90000709 Revision 02